



Transformer Energization Study Case with PAMSUITE

Manuel MARTINEZ
Paul POUJADE

21st June 2019



TRANSFORMER ENERGIZATION

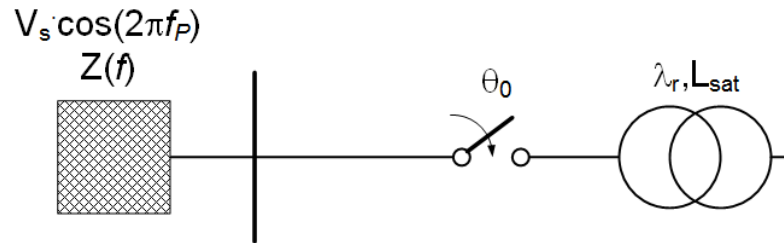

- Outputs of interest
 - Inrush current
 - RMS voltage drop at the point of interconnection (POI)
 - Resonant overvoltage at the transformer terminals
- Uncertainties on influential parameters
 - POI short-circuit power, S_{sh} and PF_{sh} → epistemic
 - Parameters of the line between POI and Tr → epistemic
 - Circuit-breaker closing-angle ($\theta_0=0-360^\circ$) → aleatory
 - Circuit-breaker closing-angle pole span ($\theta_A \neq \theta_B \neq \theta_C$) → aleatory
 - Transformer residual flux (amplitude and phase distribution) → aleatory
- Results
 - Statistical distribution: e. g., CDF of I_{inrush} , $RMS-V_{drop}$, OV
 - Probability of exceeding a threshold: e. g.: $P(\text{voltage drop} > 5\%)$

IN EMTP

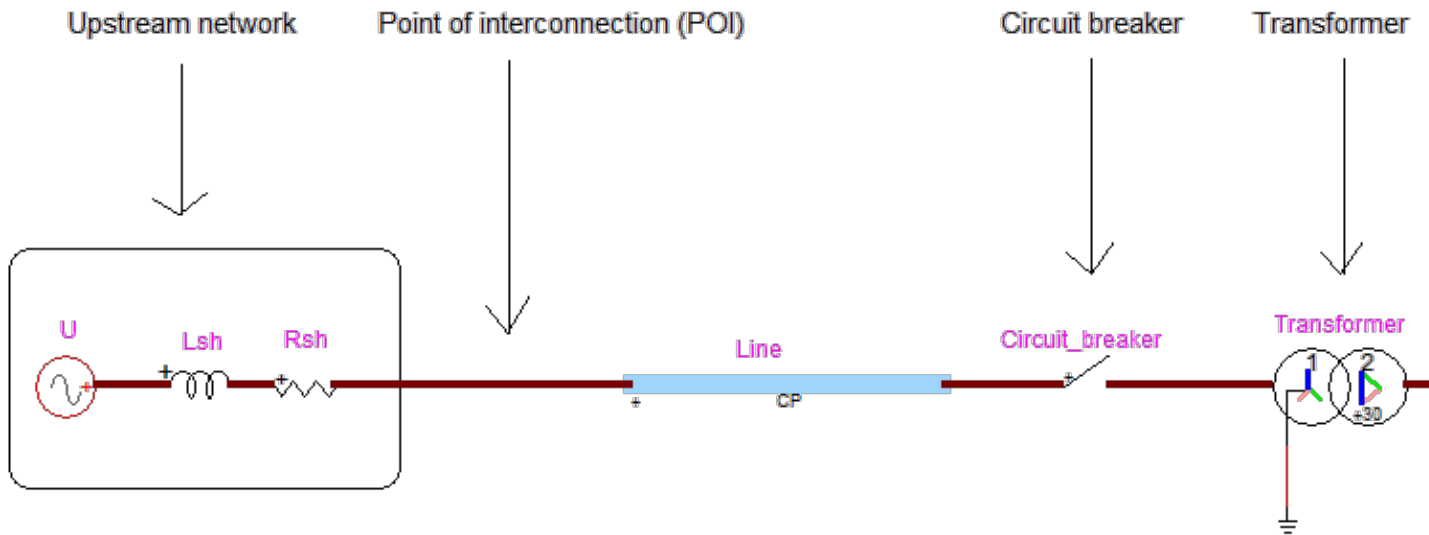

- \underline{S}_{sh} & \underline{PF}_{sh}
 - $Z_{sh} = (U^2/S_{sh})$;
 - $\underline{L}_{sh} = Z_{sh} \cdot \sin(PF_{sh}) / (2 \cdot \pi \cdot 50)$;
 - $\underline{R}_{sh} = Z_{sh} \cdot \cos(PF_{sh})$
- Line parameters: length; $\underline{R0}$, $\underline{R1}$, $\underline{C0}$, $\underline{C1}$, and $\underline{L0}$, $\underline{L1}$, per unit length
- CB: \underline{t}_A , \underline{t}_B , \underline{t}_C
- Transformer residual flux: $\underline{\Phi}_A$, $\underline{\Phi}_B$, $\underline{\Phi}_C$

ONE CASE

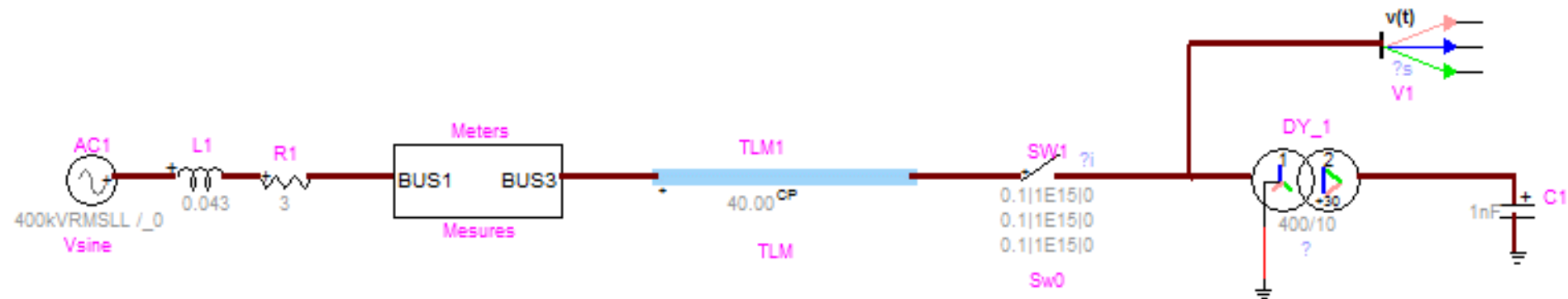

- $S_{sh}=8$ GVA & $PF_{sh}=75^\circ$
- Line parameters: 40 km, $R=$; $R_0=0.3$, $R_1=0.02$, $C_0=0.008$, $C_1=0.0126$, and $L_0=3$, $L_1=0.9$
- Circuit breaker: $t_A=t_B=t_C=100$ ms
- Transformer residual flux:
 - $\Phi_A=0.8$ pu,
 - $\Phi_B=-0.4$ pu,
 - $\Phi_C=-0.4$ pu

ONE CASE

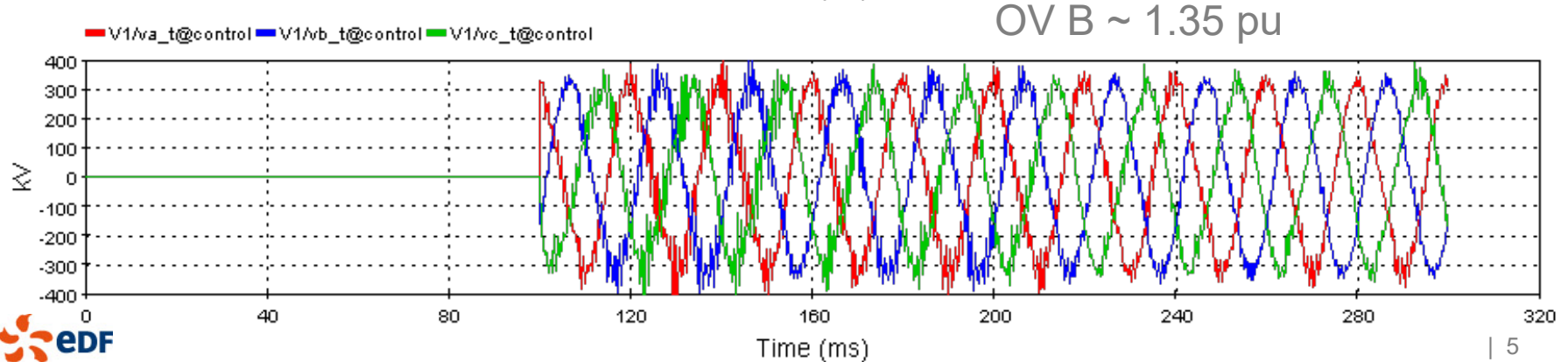
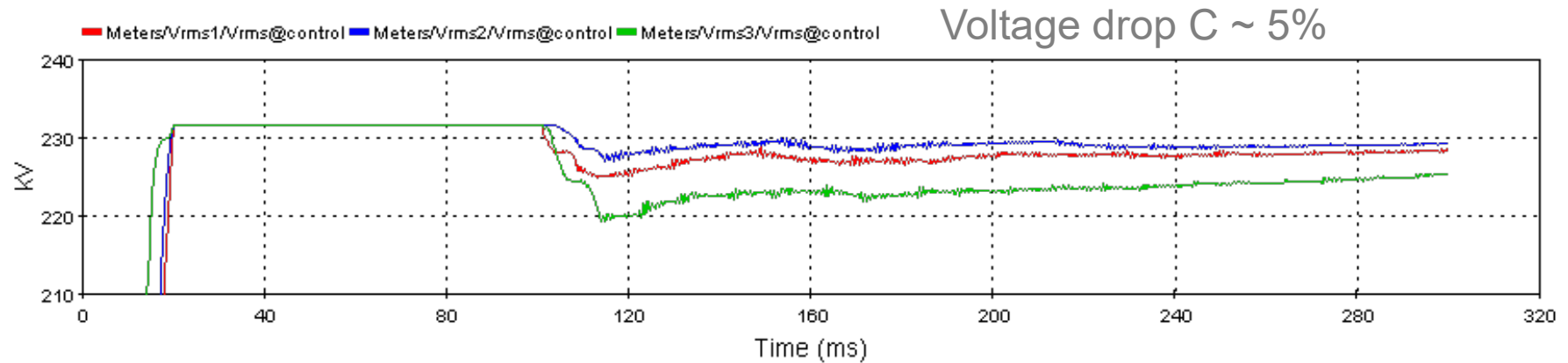
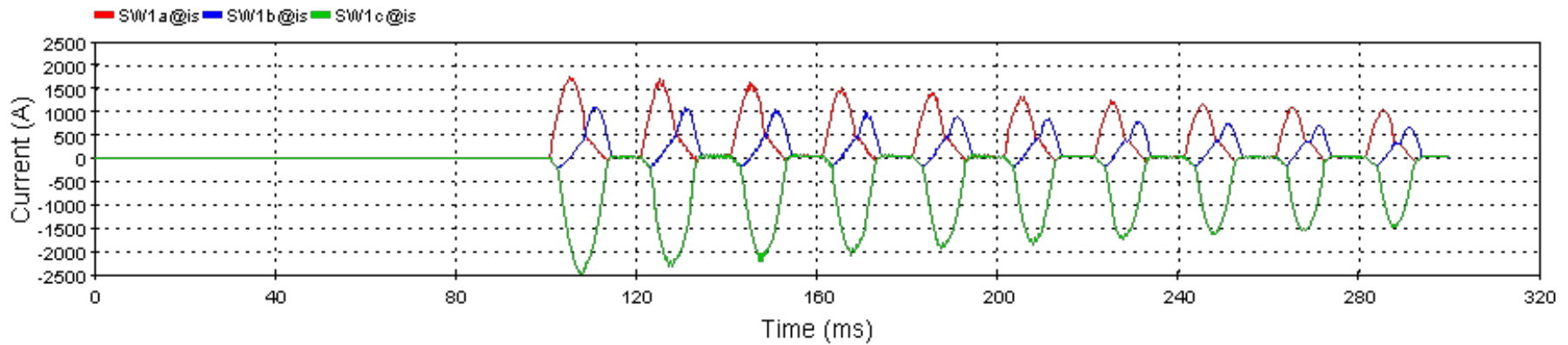

UNCERTAINTIES: INPUT

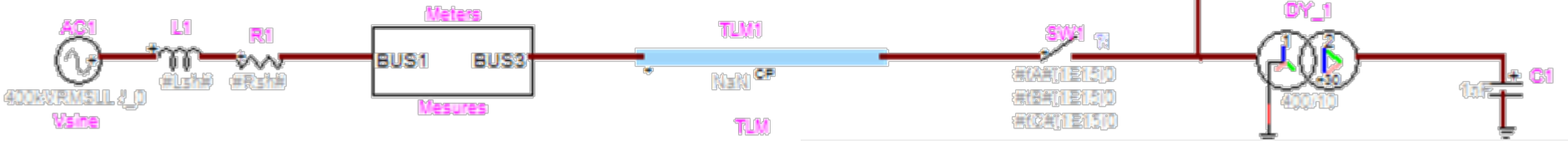

□ $S_{sh} = 8-15 \text{ GVA}$ (& $PF_{sh} = 75^\circ$)

□ Line parameters R, L, C: $\pm 5 \%$

□ Circuit breaker:

- $t_A = 100 - 120 \text{ ms}$
- $t_B \sim N(t_A, 5\text{ms})$
- $t_C \sim N(t_A, 5\text{ms})$

□ Residual flux:

- $\lambda_0 = 0-0.8 \text{ pu}$
- $\theta_0 = 0-360^\circ$
- $\lambda_k = \lambda_0 \cdot \cos(\theta + (k-1) \cdot 120^\circ)$

	Type	Name	Value	EMTP
1	U	Ssh	U[8,15]	
2	c	PF_sh	75	
3	c	line_length	40	length ~ TLM1[TLM]
4	f()	Zsh	Ur = 400e3 ...	
5	f()	Lsh	PF_sh_rad = PF_sh/360 * 2*pi ...	Lsh ~ L1[RLC]
6	f()	Rsh	PF_sh_rad = PF_sh/360 * 2*pi ...	Rsh ~ R1[RLC]
7	U	delta_R_line	U[-5,5]	
8	U	delta_L_line	U[-5,5]	
9	U	delta_C_line	U[-5,5]	
10	f()	line_R0	0.3.*(1+delta_R_line./100)	R0 ~ TLM1[TLM]
11	f()	line_R1	0.02.*(1+delta_R_line./100)	R1 ~ TLM1[TLM]
12	f()	line_L0	3.*(1+delta_L_line./100)	L0 ~ TLM1[TLM]
13	f()	line_L1	0.9.*(1+delta_L_line./100)	L1 ~ TLM1[TLM]
14	f()	line_C0	0.008.*(1+delta_C_line./100)	C0 ~ TLM1[TLM]
15	f()	line_C1	0.0126.*(1+delta_C_line./100)	C1 ~ TLM1[TLM]
16	U	t_CB_common	U[0,20E-3]	
17	N	Diff_t_CB_B	N(0,20e-3)	
18	N	Diff_t_CB_C	N(0,20e-3)	
19	f()	t_CB_0	100e-3	
20	f()	t_CB_A	t_CB_0+t_CB_common	tA ~ SW1[Sw0]
21	f()	t_CB_B	t_CB_0+t_CB_common+Diff_t_CB_B	tB ~ SW1[Sw0]
22	f()	t_CB_C	t_CB_0+t_CB_common+Diff_t_CB_C	tC ~ SW1[Sw0]
23	U	RemFluxAmplitude...	U[0,0.8]	
24	U	RemFluxAngle	U[0,2*pi]	
25	f()	RemFlux_A_pu	RemFlux_A_pu = RemFluxAmplitude_pu.*c...	
26	f()	RemFlux_B_pu	RemFlux_B_pu = RemFluxAmplitude_pu.*co...	
27	f()	RemFlux_C_pu	RemFlux_C_pu = RemFluxAmplitude_pu.*co...	
28	f()	Flux_rated	400e3.*sqrt(2./3)/(2.*pi.*50)	
29	f()	RemFlux_A	RemFlux_A_pu.*Flux_rated	Phiss01 ~ DY_1
30	f()	RemFlux_B	RemFlux_B_pu.*Flux_rated	Phiss02 ~ DY_1
31	f()	RemFlux_C	RemFlux_C_pu.*Flux_rated	Phiss03 ~ DY_1

UNCERTAINTIES: OUTPUT

- 4 highest currents

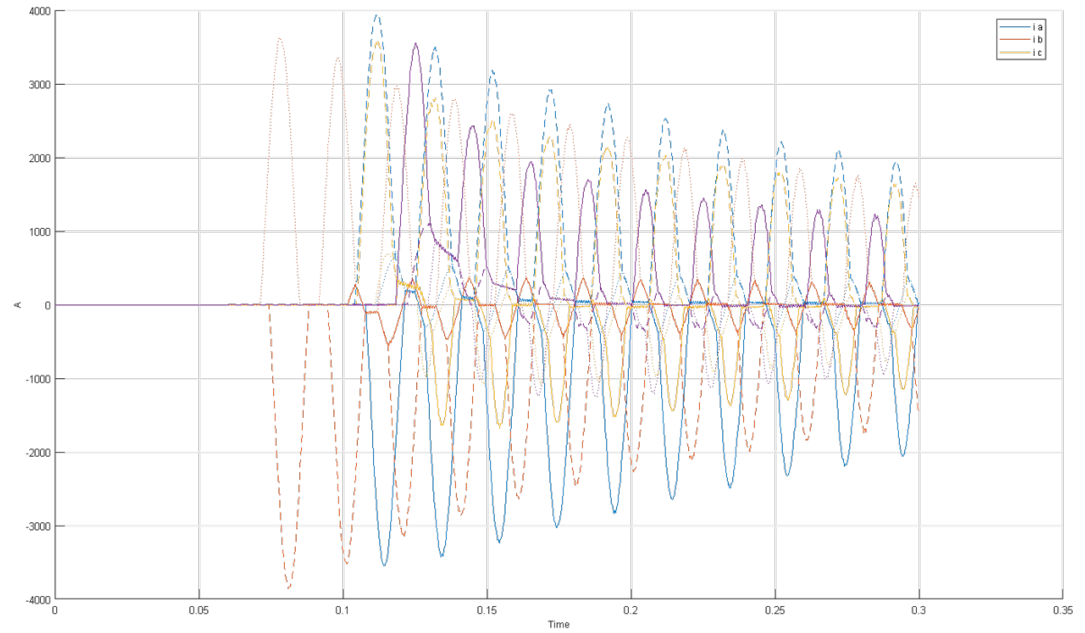

- 4 highest voltages

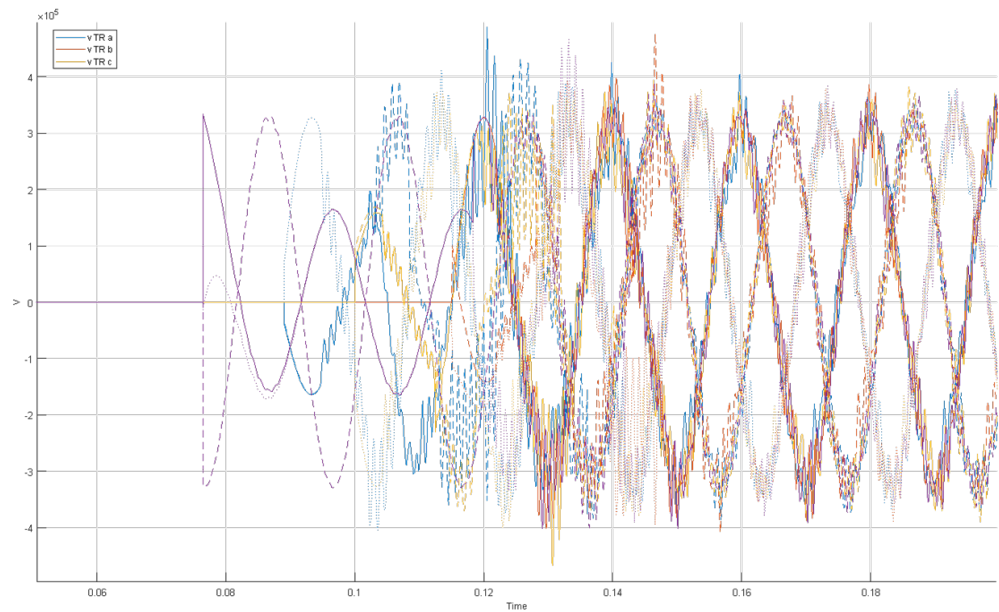

UNCERTAINTIES: OUTPUT

□ RMS voltage drop

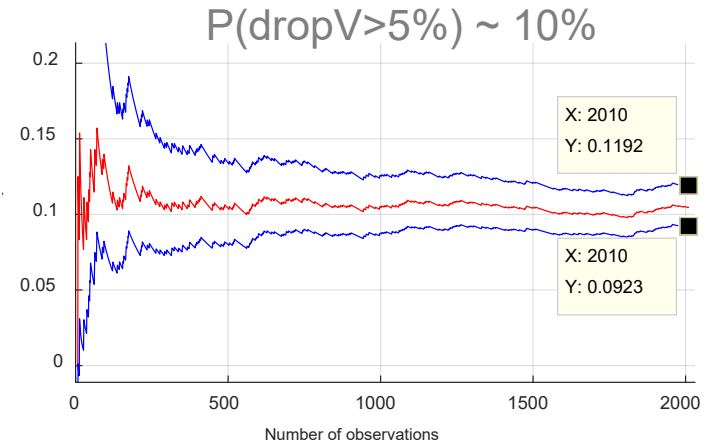
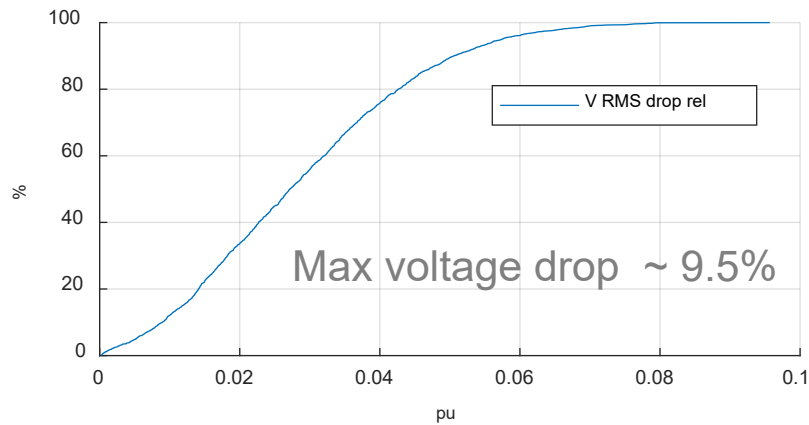

□ Resonant OV

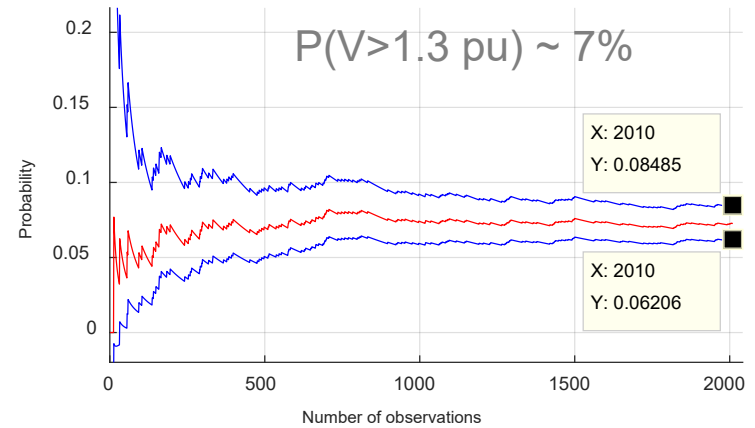
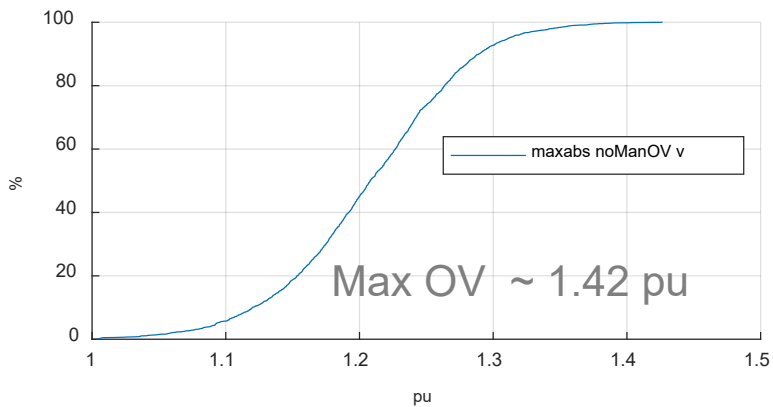

CONCLUSIONS

- The methodology to carry out transformer energization has been presented;



- Parametric simulations are needed;
- To do so, PAMSUITE, the parametric modelling toolbox for EMTP is of great help, as it enables advanced parametric calculations but is yet easy-to-use.

**Thank you
Questions?**